

# **SF600/SF600Plus**

## **Serial Flash Programming solutions**

### **Specification**

#### **V2.6**

**The Innovative solution to update the Serial Flash on board and Offline**

- **High performances**
- **USB High speed support**
- **In Circuit Programming (program on board SPI Flash)**
- **Socket Programming (program SPI flash in the socket)**
- **Start Button function**
- **Standalone mode (SF600Plus): Update the Serial flash without computer**
- **Support single, Dual and Quad IO**
- **Three software optimized interfaces:**
  - **Engineering Interface for expert**
  - **Command Line for automatic control**
  - **Production interface for operator**
- **Multi-Programmiers support through USB**
- **Friendly and powerful tool with free life time update via Website**
- **Portable programmer**
- **Advanced I/O control**

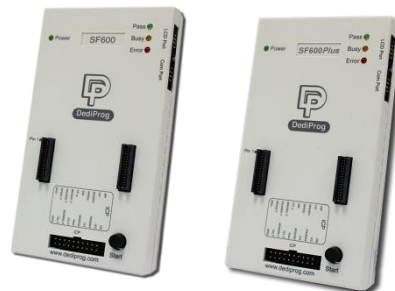

## Table of Content

<b>I. Products comparison .....</b>	<b>2</b>
<b>II. SF600 and SF600Plus description.....</b>	<b>3</b>
2.1 Interface description .....	3
2.2 ICP Header description .....	5
2.3 Application Header.....	7
2.3.1 Backward compatibility with SF100 .....	7
2.3.2 Application Universal Header.....	7
2.3.3 Pin Header pitch .....	7
<b>III. Programming methods .....</b>	<b>8</b>
3.1 In Circuit Programming.....	8
3.2 SPI bus in High Impedance .....	8
3.3 SPI bus isolation circuit.....	8
3.4 Backup Boot Flash method.....	9
3.5 Socket Programming .....	10
<b>IV. SF600 and SF600Plus software .....</b>	<b>12</b>
4.1 USB mode.....	12
4.1.1 Engineering User Interface.....	12
4.1.2 Command line Interface .....	13
4.1.3 Production User interface .....	14
4.2 Standalone mode (SF600Plus) .....	15
4.2.1 Project Preparation .....	15
4.2.2 Standalone programming.....	15
<b>V. Specification .....</b>	<b>16</b>
5.1 USB Connector .....	16
5.2 DC and IO characteristics.....	16
5.2.1 Socket DC Characteristics .....	16
5.2.2 ICP DC and AC characteristics.....	16
5.2.3 ICP timing .....	19
5.2.4 Host PC requirements .....	20
<b>VI. Programming Performance .....</b>	<b>21</b>
<b>VII. Revision History.....</b>	<b>22</b>

### **Important notice:**

This document is provided as a guideline and must not be disclosed without consent of DediProg. However, no responsibility is assumed for errors that might appear. DediProg reserves the right to make any changes to the product and/or the specification at any time without notice. No part of this document may be copied or reproduced in any form or by any means without prior written consent of DediProg.

## I. Products comparison

The Universal Programmers available on the market are not optimized for the Serial Flash and offer low performances for high price. DediProg team has therefore developed the optimum solutions to cover all our customers' needs.

**Table1: Comparison table**

Features	SF100	SF600	<b>NEW</b> SF600Plus
Support all Serial Flash	V	V	V
USB 2.0 Full speed	V		
USB 2.0 High speed		V	V
In Circuit Programming	V	V	V
Socket programming		V	V
Standalone mode			V
Start Button feature		V	V
Multi-Programmers USB	V	V	V
Engineering GUI	V	V	V
Command Line	V	V	V
Production GUI	V	V	V
Backup Boot Flash	V	V	V
Single IO	V	V	V
Dual IO		V	V
Quad IO(ICP mode only)		V	V

## II. SF600 and SF600Plus description

SF600 and SF600Plus have been designed to offer the best possible performances to program the SPI Flash in different conditions.

### 2.1 Interface description

*Fig 1: SF600/SF600Plus Programmer*

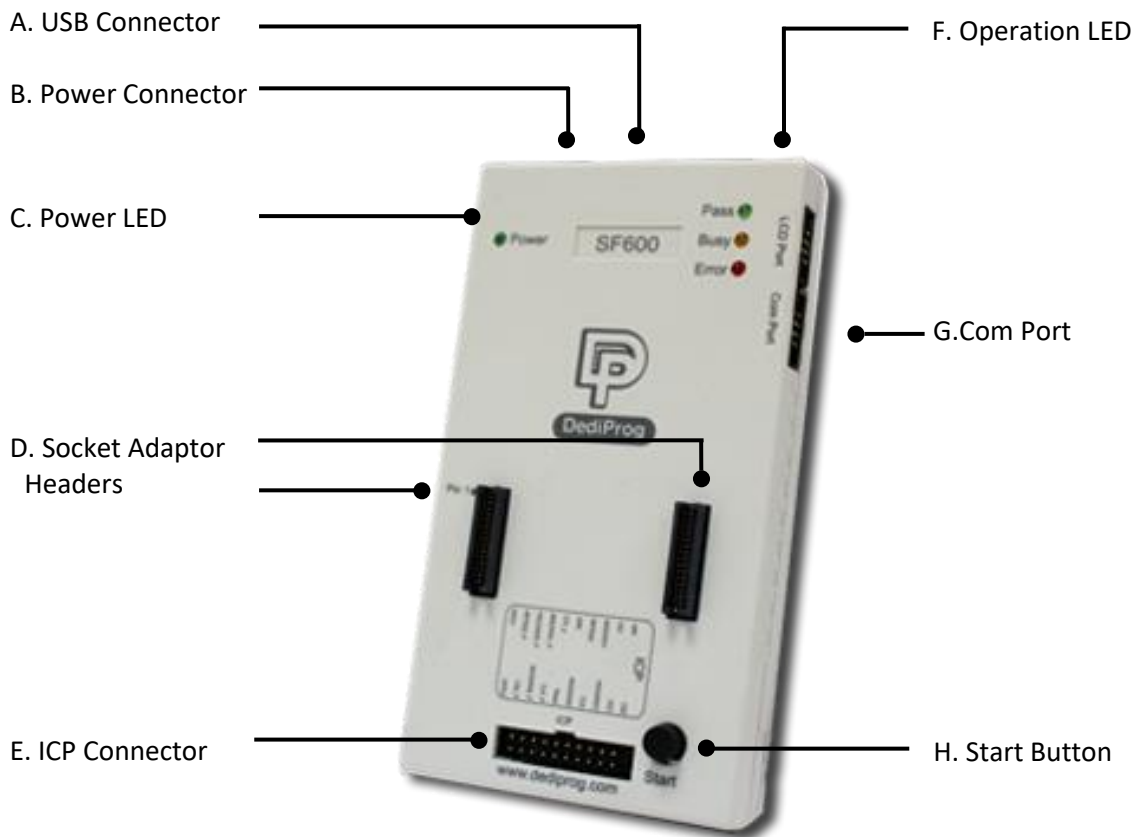

#### A. USB Connector

USB connector is used to communicate with the SF software during the USB mode or to provide the power during the standalone mode.

#### B. Power Connector

Connect power adaptor to SF600/SF600Plus when executing standalone programming.

#### C. Power LED

Power LED shines when SF600/SF600Plus is powered by USB or power adaptor.

#### D. Socket Adaptor Headers

Plug the DediProg socket adaptors and program the Serial flash off line. DediProg is providing different socket adaptors to fit the market SPI Flash packages. Review the socket adaptor available on DediProg website.

**Fig 2: Socket adaptors**

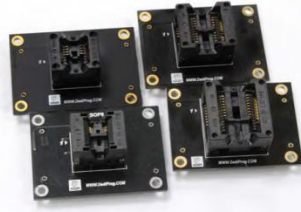

#### E. ICP Connector

ICP connector is used to connect ICP cable when executing ICP programming.

#### F. Operation LED

- **Red Led:** error
- **Orange Led:** operation on going
- **Green Led:** pass

#### G. Com Port

The Com Port design is for integrating SF600/SF600Plus with customer's system. All programmer pin outs (except 5V and NC) are default with Low status. Once customer/system sends a High signal to trigger START which needs press and hold one second and make the programmer working (i.e. BUSY becomes High status accordingly), SF600/SF600Plus will also feedback PASS or FAIL result with High signal after programming.

**NOTE:**

The input voltage range is between 3.5V to 6.5V which means High. The voltage cannot over 6.5V that may cause the component damage.

**Table 2: Pin Out**

<b>1</b> <b>GND</b>	<b>2</b> <b>NC</b>
<b>3</b> <b>5V</b>	<b>4</b> <b>START</b>
<b>5</b> <b>FAIL</b>	<b>6</b> <b>PASS</b>
<b>7</b> <b>BUSY</b>	<b>8</b> <b>NC</b>

#### H. Start Button

The Start button is operations from the programmer either in USB mode. By pressing and hold 2 seconds the start button, the SF600 and SF600Plus starts to execute the operation procedures defined in the software Batch configuration when working in USB mode or in the project pre-loaded to the SF600Plus when working in standalone mode.

## 2.2 ICP Header description

The In Circuit Programming Header and cable are used to program the on board Serial Flash. The flat cable is flexible and convenient to manipulate. It must be kept as short as possible to not impact the signal quality. Even if SF600 and SF600Plus strong buffers can drive high capacitance, the communication failure can occur due to weaker driving capability of the on board Serial Flash. In case of communication problems, try to reduce the bus frequency from the software interface.

For customization of the ICP-cable (number of signals, pin out assignment or connector size), please contact DediProg. DediProg is providing additional accessories to fit your target board like:

### A. ICP split cable:

You can connect each signal individually according to your own pins assignment.

### B. SO Test Clip:

You can connect the SF600/SF600Plus directly on the Serial flash SO package (SO8N, SO8W, and SO16W)

**Table 3: SF600 and SF600Plus Pin Header description:**

<b>1</b>	Vpp	CS2	<b>2</b>
<b>3</b>	CS1	Vcc	<b>4</b>
<b>5</b>	MISO/DQ1	Hold/DQ3	<b>6</b>
<b>7</b>	Wp/DQ2	CLK	<b>8</b>
<b>9</b>	GND	MOSI/DQ0	<b>10</b>
<b>11</b>	NC	Reset/IO3	<b>12</b>
<b>13</b>	NC	NC	<b>14</b>
<b>15</b>	NC	NC	<b>16</b>
<b>17</b>	NC	NC	<b>18</b>
<b>19</b>	GPIO1	GPIO2	<b>20</b>

**Table 4: Description of the signals:**

Pin Number	Name of the signals	Description
1	<b>Vpp</b>	High voltage applied on the SPI Flash to speed up the programming and erasing operations.
2, 3	<b>CS1, CS2</b>	Chip select of two Serial Flashes. Serial Flash 1 or 2 can be selected from the software.
4	<b>Vcc</b>	Vcc is used to supply the application SPI Flash. The Vcc level can be adjusted from the software. A diode protects the SF600/SF600 <i>Plus</i> Vcc from the application Vcc.
5	<b>MISO/DQ1</b>	Data out from the application memory (master in slave out) when memory work in single IO mode. Bi-directional when memory works in Dual or Quad IO mode.
6	<b>Hold/DQ3</b>	Driven High when Hold function is active. Bi-directional when memory works in Quad IO mode.
7	<b>Wp/DQ2</b>	Driven High when Wp function is active. Bi-directional when memory works in Quad IO mode.
8	<b>CLK</b>	SPI clock signal
9	<b>GND</b>	GND is the common ground shared between application and programmer
10	<b>MOSI/DQ0</b>	Data in of the application SPI Flash (master out slave in) when memory work in single IO mode. Bi-directional when memory works in Dual or Quad IO mode.
12	<b>Reset/IO3</b>	Open drain output driven low prior any SF600/SF600 <i>Plus</i> operation. Reset/IO3 can be used to turn on the application isolation circuit or reset the target system in order to drive the Serial bus in High Impedance.
11, 13, 14, 15, 16, 17, 18	<b>NC</b>	Not connected
19, 20	<b>General purpose I/O</b>	General I/O can be used for customization.

## 2.3 Application Header

### 2.3.1 Backward compatibility with SF100

The SF600 and SF600*Plus* pin header assignment has been changed versus the SF100 in order to support the new Serial Flash features like Quad IO and to be compatible with others DediProg development tools like EM100pro SPI Flash emulator and Backup Boot Flash tools. If your application has been designed for the SF100, DediProg is providing with the SF600 and SF600*Plus* an adaptor to be backward compatible.

### 2.3.2 Application Universal Header

For new application design, DediProg strongly recommend to implement the universal Header so you can benefit of all the development tools available and future features of the Serial Flash and controllers.

- One or two Serial Flash programming
- Single, dual and Quad IO programming
- Controller Reset mode

**Table 5: Universal Pin Header for application design**

<b>1</b>	Vpp	CS2	<b>2</b>
<b>3</b>	CS1	Vcc	<b>4</b>
<b>5</b>	MISO/DQ1	Hold/DQ3	<b>6</b>
<b>7</b>	Wp/DQ2	CLK	<b>8</b>
<b>9</b>	GND	MOSI/DQ0	<b>10</b>
<b>11</b>	NC	Reset	<b>12</b>

\*NC: Not connected

It is recommended to keep the Header 2\*6 even if some signals are unused (Vpp, CS2, Hold, Wp, reset). The header will stay compatible with the female connector supplied by default with the SF600 and SF600*Plus*.

Pin 11 can be used as insertion mistake proof pin. To support this protection of wrong insertion, the pin 11 has to be cut in the application and the corresponding hole of the cable connector must be filled accordingly.

### 2.3.3 Pin Header pitch

The default cable and female connector provided with SF600 and SF600*Plus* is a 2.54mm pitch.

For space saving reason, you may decide to implement a 1.27mm pitch connector on your application board. DediProg proposes an adaptor board to convert from 2.54mm to 1.27mm.



## III. Programming methods

### 3.1 In Circuit Programming

The SF600 and SF600Plus programmers have been designed to meet the strong and growing demand of serial flash users to program and update the memories soldered on board during development, production, and field manipulation or repairing with high performance and low cost.

**Important:**

Socket adaptor and In Circuit Programming cannot be used in the same time. To use the In Circuit programming, the socket adaptor has to be removed.

SF600 and SF600Plus can support dual and quad IO programming offering the shortest programming time even if the application board total capacitance do not permit high frequency.

Before trying to update the Serial Flash soldered on Board, make sure that the SPI controller and the application are compatible with the In Circuit Programming method to avoid any conflict with the programmer.

**Fig 3: SF600/SF600Plus connected to the application header**

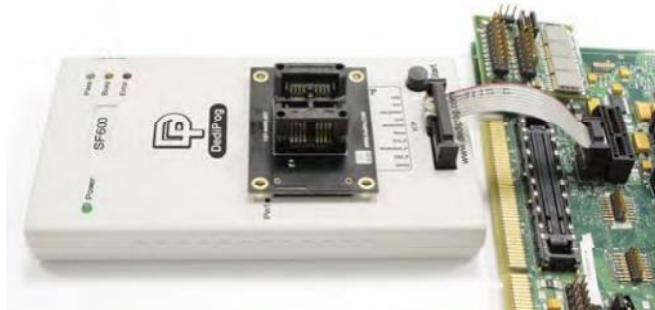

### 3.2 SPI bus in High Impedance

The SF600/SF600Plus reset signal can be used to reset the target board and switch the application controller in reset mode. User must check if the SPI bus is released in high impedance during this mode to prevent any conflict between the programmer and the application controller. In this mode, the on board flash is supplied by the application.

### 3.3 SPI bus isolation circuit

If the application controller does not release the SPI bus in high impedance during reset then an isolation circuit (MOSFET, switch, multiplexer...) must be designed in order to isolate the programmer and serial flash from the application controller during the update.

DediProg has published an Application Note and reference schematic to help designers to implement the In Circuit Programming method and will be pleased to answer any of your questions on this subject.

**Code programming or Update flexibility:**

- For code trials during Research and Development (R&D)
- For Production programming
- For application code update or customization in warehouse
- For repairing or update in the field

### 3.4 Backup Boot Flash method

SF600 / SF600Plus can also be used together with DediProg backup boot flash modules so that it forces the application to boot from the backup flash located in the backup boot flash module instead of the soldered SPI flash on the application which it is disabled. The backup serial flash can then be accessed at any time by the SF600 / SF600Plus without any possible conflict with the application controller. In this case, SF600 / SF600Plus cannot update directly the on board Serial Flash to avoid conflict with the controller.

**Applications:**

- A. Development purpose** as the system can boot from the backup Flash for the code trials. Engineer can update safely the backup Flash with new code and without any conflict risk with the application controller.
- B. Repair purpose** as the system can still boot from a backup memory even if the on board Serial flash is corrupted. The technician can use the application flash update tools after the boot to update the on board Serial flash.

**Remark:** Pin header adapter need to be used

**Fig 4: Backup Boot Flash (BBF) connected to SF600 and SF600Plus**

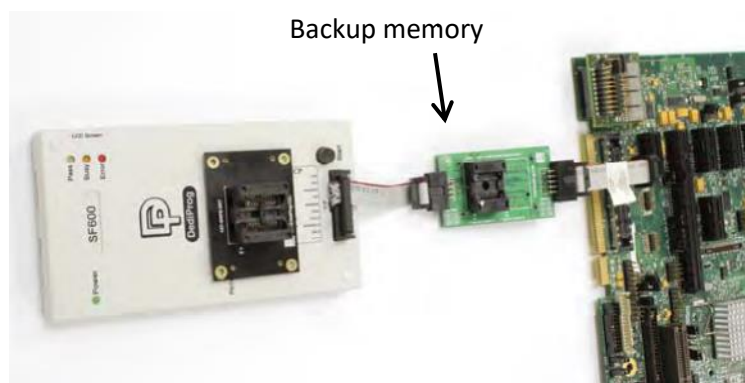

### 3.5 Socket Programming

The SF600 and SF600Plus have been designed to support the DediProg socket adaptors and offer the socket programming flexibility. Different sockets adaptor are provided to fit the different Serial Flash packages proposed in the market. Please note that socket mode only supported Single and Dual IO.

#### A. For development:

Socket programming can be used during development when an engineering socket is soldered in the target application board so that Serial Flash can be manually removed and programmed in the SF600 and SF600Plus socket. DediProg supplies engineering sockets which are footprint compatible with the SPI Flash.

#### B. For Production:

Socket programming can be used to program the Serial Flash before soldering. DediProg software supports multi-programmers through USB to program few serial Flash in parallel and SF600 and SF600Plus also supports Standalone mode.

**Fig 5: SF600/SF600Plus with Socket adaptor**



#### Important:

Socket adaptor and In Circuit Programming cannot be used in the same time. To use the socket programming, the in Circuit Programming cable has to be unconnected.

**Note:**

The new socket adaptor has a white triangle marker on the left and lower side of the socket. Shown as below

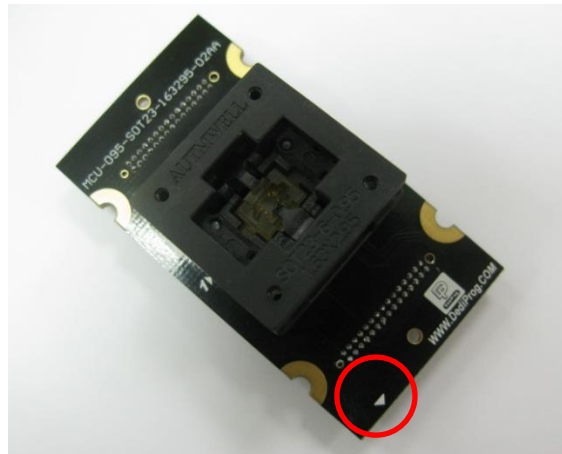

To avoid plugging the wrong direction to the socket header, please ensure the marker to aim at the Pin 1 position.

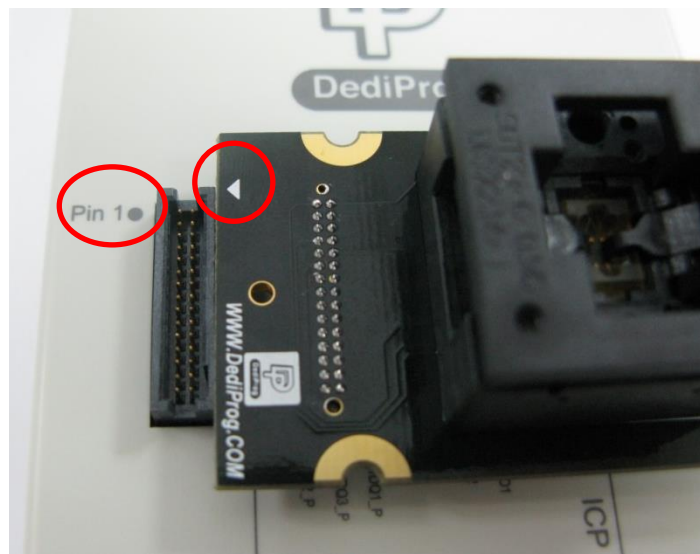

## IV. SF600 and SF600Plus software

### 4.1 USB mode

In USB mode, user can control the programmer operations via a friendly interface. He can load a file, blank check, program and verify the target Serial Flash. Batch button provides an easy way to perform more than one operation in one click.

User can also edit the buffer, files and SPI Flash content and compare.

DediProg provides three different users interface to fit better our customers' needs. For more information on the SF600 and SF600Plus software, please refer to the user manual.

#### 4.1.1 Engineering User Interface

The engineering user interface has been designed to offer the expert features for engineers during development. Please note the “Download Prj” button is only for SF600Plus. The details for the download project feature are described in DediProg user manual.

**Fig 6: SF600 Engineering GUI**

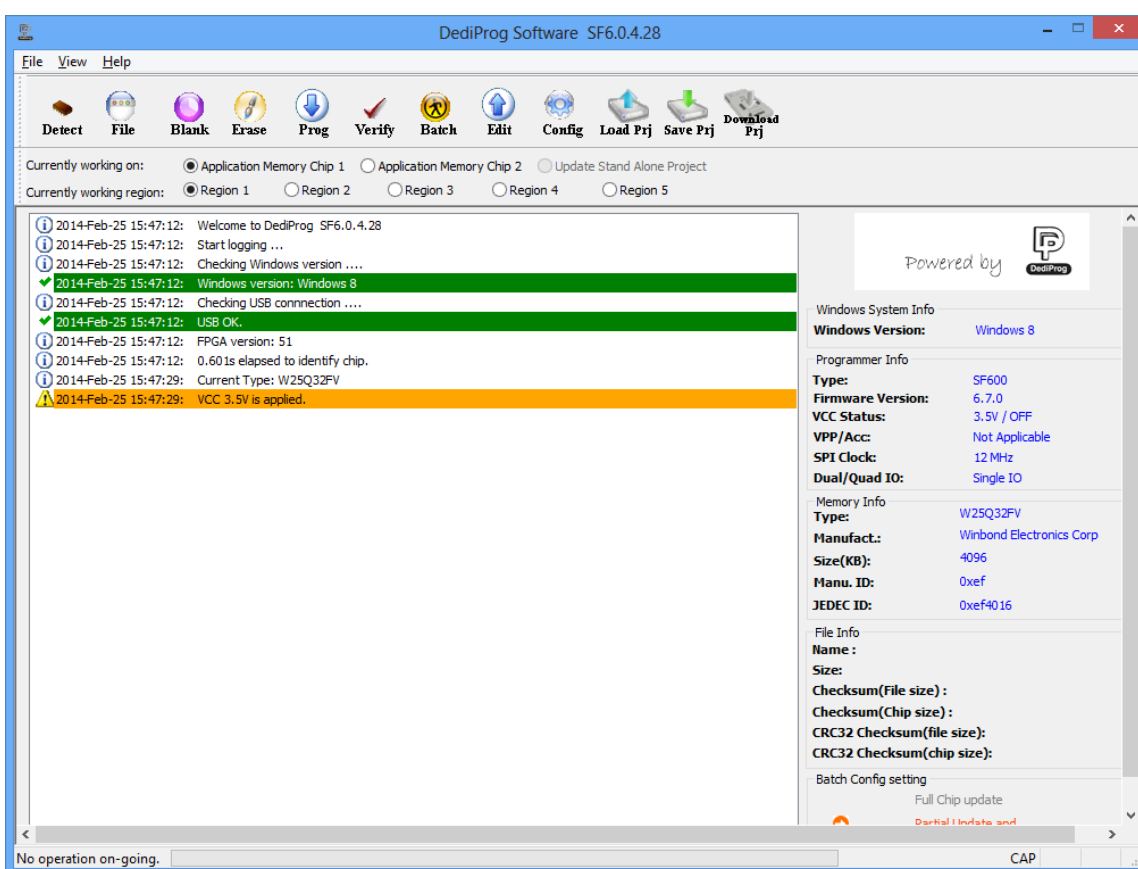
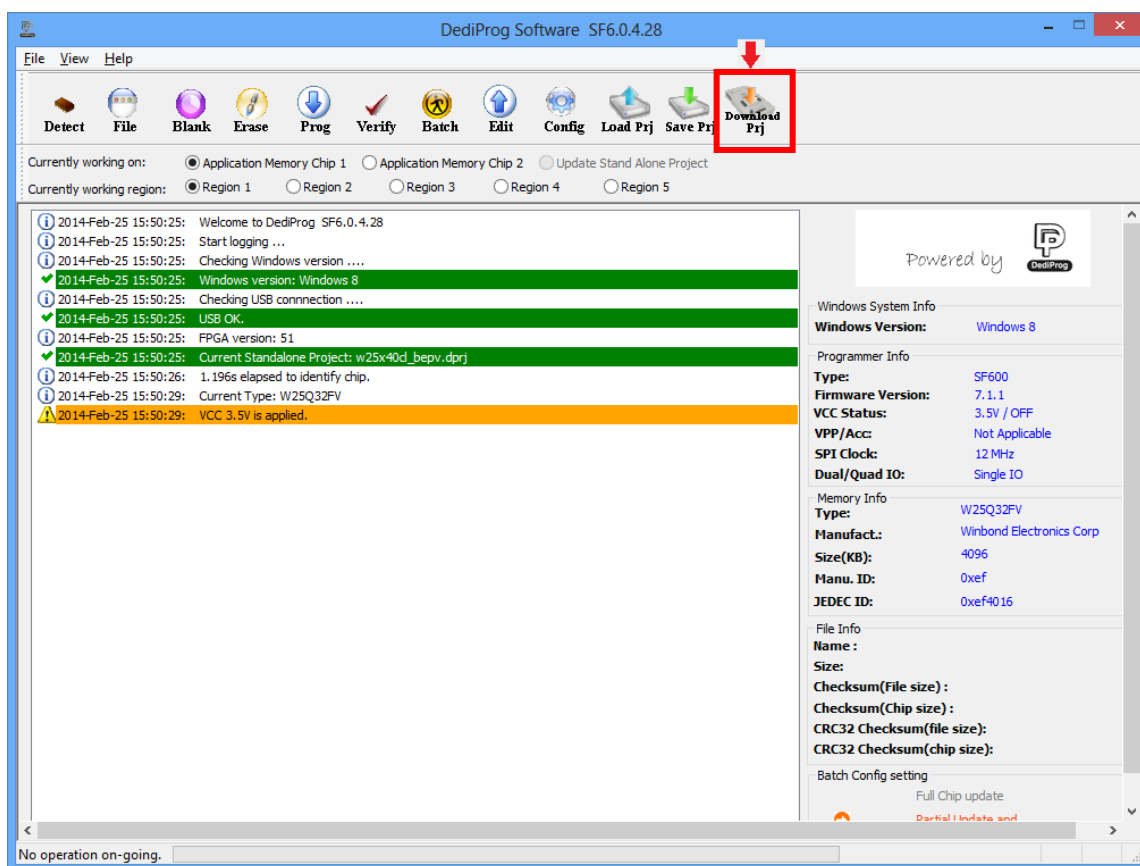

Fig 7: SF600Plus Engineering GUI.



#### 4.1.2 Command line Interface

The command line interface has been designed to offer a faster user control of the programmer or an automatic control of the programmer from other software.

##### Faster control:

User can quickly perform some repetitive operations just by typing the command on our Window DOS interface.

##### Automatic control:

The command line can be called by other software to take the control over the programmer.

Benefits:

- SF600 and SF600Plus can be controlled by the **compiler** in order to automatically program the Serial Flash with the new code for trials
- SF600 and SF600Plus can be integrated in your production line and be controlled by the **In Circuit Tester** to program the on board serial flash after the testing has been successfully performed.

Fig 8: Window DOS interface

```

C:\>
C:\>set path=%path%;"c:\program files\dedipro\inc\dedipro\programmer"

C:\>dpnd -uc:\MM_55.bin
DpCmd 1.1.0, Engine Version: 2.0.33.
Last Built on Nov 22 2006
Copyright (C) 2006 DediProg. All rights reserved.

M25PE80 detected.

Auto sequences Operating, please wait ...
Time elapsed: 26.608s
Automatic program OK
Checksum(File): 0000
C:\>dpnd -pc:\MM.bin -a0x010
DpCmd 1.1.0, Engine Version: 2.0.33.
Last Built on Nov 22 2006
Copyright (C) 2006 DediProg. All rights reserved.

M25PE80 detected.

Reading, please wait ...
Time elapsed: 4.596s
Read OK
Erasing, please wait ...
Time elapsed: 15.422s
Erase OK
Programming, please wait ...
Time elapsed: 8.573s
Program OK
Checksum(File): 00aa
C:\>

```

### 4.1.3 Production User interface

The production user interface has been designed to offer the optimum interface to control volume programming:

- Simple interface to fit to the operator needs
- Project loading to reduce the human errors
- Monitor multiple programmers operation in one window
- Control your ongoing project performances (counters, failure rate...etc.)

Fig 9: Production GUI

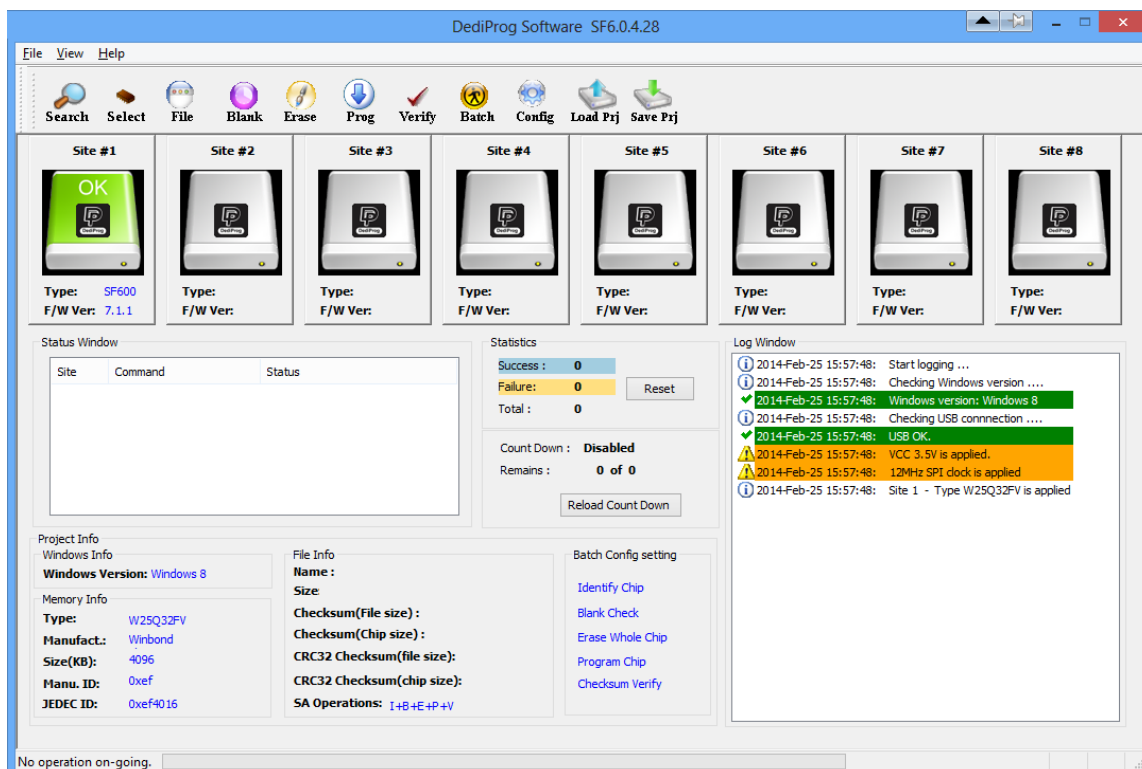

## 4.2 Standalone mode (SF600Plus)

The SF600Plus has been designed to work in standalone mode that is optimized for production as each programmer does not require to be connected to the computer. Before to work in standalone mode, user needs to download the existed project from PC to SF600Plus embedded memory.

### 4.2.1 Project Preparation

In order to perform standalone programming, the contents and the programming operation procedures have to be pre-downloaded to the SF600Plus embedded memory through the USB with the software provided by DediProg.

#### Prepare a standalone programming project

- A. Open DediProg Production Software.
- B. Select IC brand and part number.
- C. Load the programing file.
- D. Click “Config” Icon to set programming flow.
- E. Save dprj file to PC.
- F. Click “Download Prj” to download project to SF600Plus embedded memory
- G. Download project successful

**Fig 10: SF600Plus download project successful interface**

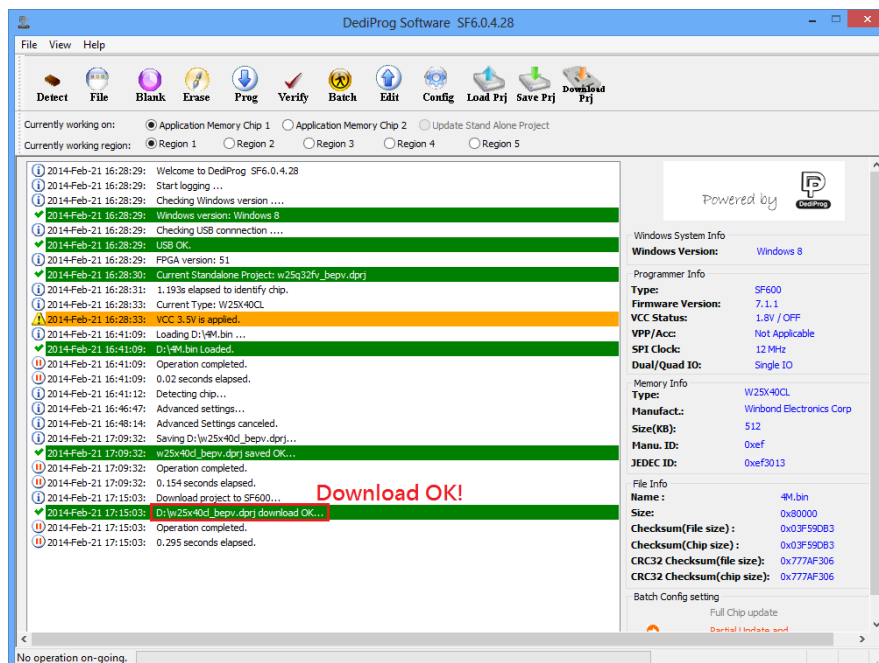

### 4.2.2 Standalone programming

When the project is available in the SF600Plus embedded memory, the user can run the project from push the start button.



## V. Specification

### 5.1 USB Connector

The USB connector type A is available to communicate with the computer tool or to supply the programmer in Standalone mode. When in Standalone mode, the SF600Plus has to be supplied through the USB connector or the 5V power jack. This could be achieved by:

- Connecting the SF600Plus to a computer for the USB power
- Connecting the SF600Plus to a standard USB Hub (500mA min)
- Connecting the SF600Plus to the 5V/1A power adaptor through the power jack

USB Power supply specification:

- Vdd = 5V ± 5%
- Idd min = 500mA

### 5.2 DC and IO characteristics

#### 5.2.1 Socket DC Characteristics

User can adjust the power supply of the target Serial Flash from the software interface. The Vcc can be set from 1.8V to 3.8V.

The SPI signals levels are generated according to the Vcc selected.

#### 5.2.2 ICP DC and AC characteristics

The ICP connector is a 10x2 pin header straight type with 2.54mm pitch. It is used to control the application SPI Flash, and if necessary supply the SPI Flash, provide the high voltage to the SPI Flash, or reset the application chipset, etc.

**Table 6: SF600 and SF600Plus Pin Header description:**

<b>1</b>	Vpp	CS2	<b>2</b>
<b>3</b>	CS1	Vcc	<b>4</b>
<b>5</b>	MISO/DQ1	Hold/DQ3	<b>6</b>
<b>7</b>	Wp/DQ2	CKL	<b>8</b>
<b>9</b>	GND	MOSI/DQ0	<b>10</b>
<b>11</b>	NC	Reset/IO3	<b>12</b>
<b>13</b>	NC	NC	<b>14</b>
<b>15</b>	NC	NC	<b>16</b>
<b>17</b>	NC	NC	<b>18</b>
<b>19</b>	GPIO1	GPIO2	<b>20</b>

### A. Application SPI Flash supply: Vcc

Specification for the ICP Vcc pin:

- Vcc is set at 3.3V by default and can be adjusted down to 1.8V from the software interface
- Icc max supplied = 100mA

The application SPI Flash can be supplied by two different sources:

- a) by the programmer via ICP Vcc pin
- b) by the application according to the SPI Flash specification

**The SF600 and SF600*Plus* have been designed with a Serial diode on the Vcc to protect against any conflict with the application Vcc.**

### B. SPI signals management: CS1, CS2, CLK, MISO, MOSI, DQ0-4, IO, reset/IO3

The SPI signals are used to communicate with the application SPI Flash with a high frequency (up to 25MHZ). The frequency can be also adjusted from the software interface. The signals are CMOS compatible and are switched in High Impedance when not used. The SPI signals are turned in Low impedance after reset has been driven low.

**Table 7: DC specification for SPI signals and IO**

Symbol	Parameter	Test condition		Value	Unit
		Vcc(V)	Io(mA)		
Vih	High Level Input Voltage	2.7V to 3.6V		2V	V min
		2.3V to 2.7V		1.7V	V min
		1.65V to 1.95V		0.65XVcc	V min
Vil	Low Level Input Voltage	2.7V to 3.6V		0.8V	V max
		2.3V to 2.7V		0.7V	
		1.65V to 1.95V		0.35XVcc	
Ioh	High Level Output current	3V	-24mA		mA
		2.7V	-12mA		mA
		2.3V	-12mA		mA
		1.65V	-4mA		mA
Iol	Low Level Output current	3V	24mA		mA
		2.7V	12mA		mA
		2.3V	12mA		mA
		1.65V	4mA		mA
Cap	Capacitance			10nF	nF typ

This specification is relative to individual capability of one signal.

ESD high performance protection compliant with IEC61000-4-2 level 4: 15kV (air discharge)  
8kV (contact discharge)

**Remark:** the total capacitance added on the application SPI bus will also depend on the ICP cable length. The ICP cable length must be reduced at the minimum. The SPI flash output buffer capability (MISO) is limited compared to the programmer performances. So even if the programmer is able to drive high capacitance, the Serial Flash soldered on the application will probably not (information read from SPI Flash will be wrong).

### C. Smart management of the SPI Flash Vcc and SPI signals

In order to minimize the impact of the ICP method on the chipset and application board, the programmer supplies the application Serial Flash with Vcc and SPI signals only during the programmer and Serial Flash operations.

#### Advantages:

- a) The programmer is plugged on the application board with Vcc OFF and SPI signals in High Impedance to avoid inrush current.
- b) All the ICP pins are protected with ESD high performance protections to discharge the Electronics charge before the connection and protect the application.
- c) The Serial Flash Vcc and SPI signals are provided only when the user send the command and are switched OFF automatically when the operation is completed. Therefore, the programmer is transparent for the application and can be kept connected during application trials.

### D. High voltage supply: Vpp/Acc

Specification for the Vpp pin

Vpp = 5V to 12V

Ipp max = 70mA

The Vpp high voltage can be supplied by the programmer and used to speed up programming and erasing of the application Serial Flash if this feature is supported by the Serial Flash supplier.

The Vpp supply will be applied automatically by the programmer on the Vpp pin only during erase, write, or programming operations and only if the Vpp option has been enabled on the software. The programmer will also control the Vpp voltage level according to the Serial Flash connected and its specification.

### E. I/O management: IO1, IO2, Reset/IO3

Two general IO are available on the ICP connector and one Reset for custom needs. The IOs and reset are in High Impedance (HZ) state if there is no software operation ongoing.

**Reset/IO3:** The reset/IO3 pin is an open drain output which can be used to reset the target system or turn off the isolation circuit.

**Fig 11: Circuit diagram:**

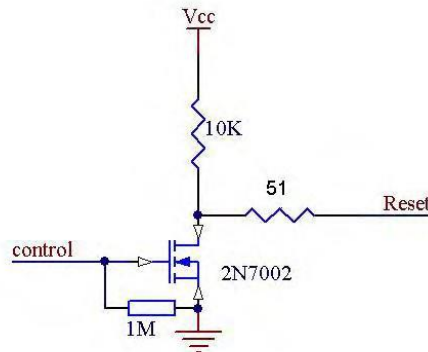

**IO:** The IO signals are in input mode by default. Behavior to be customized.

**For the DC characteristics of IO1 and IO2 please refer to the DC table.**

**ESD high performance protection** compliant with IEC61000-4-2 level 4: 15kV (air discharge) 8kV (contact discharge)

### 5.2.3 ICP timing

The IO and reset have been designed to set the application in programming mode before applying the SPI signal. They can be used to reset the target application, to turn OFF MOSFET and isolate the SPI bus when programmer is working.

**A. If No programmer operation is on going**

All our SF600 and SF600Plus outputs are equivalent to high impedance.

**B. When an operation is requested on the user interface**

- IO1, IO2 are kept in Input by default (High Impedance)
- Reset/IO3 signals are driven Low.

**C. 3 ms after Reset is switched to Low Impedance, the SPI outputs are switched in low impedance too.**

- CS1 and CS2 are driven high
- Clock and MOSI are driven low
- DQ0-3 are driven low if Quad IO outputs is enable
- Hold, Wp are driven High if single IO mode is used

**D. The programmer is then ready for the communication with the Serial Flash.**

So designer can use the Reset signal to reset or switch the application Serial bus in High impedance. Application controller or circuitry will have a delay of 3ms between Reset is driven low and Programmer SPI outputs are switched from High Impedance to Low Impedance. SPI communication starts 6ms after reset has been driven low.

**E. When operation on the memory is finished**

The SF600 and SF600Plus are switched in High impedance so the application board can boot with SF600 and SF600Plus connected without conflict.

**Fig 12: IO and SPI timing**

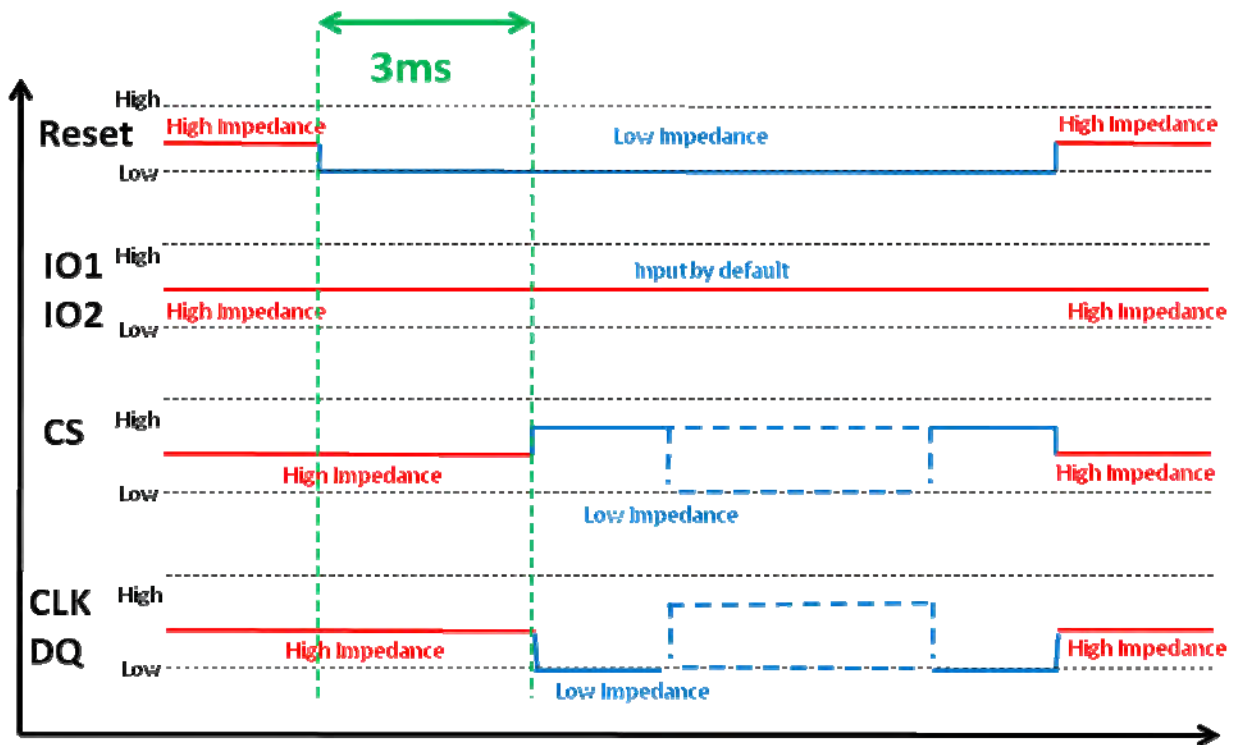

**5.2.4 Host PC requirements**

The SF600 and SF600Plus interfaces with IBM compatible PC's through the USB 2.0/1.1 port. This gives full compatibility with the latest PC's, notebooks and portables.

**System Requirements:**

- PC with Windows XP / Vista / Win7/ Win8 / Win 8.1
- Hard disk with at least 64 MB free space.

**System Interface:**

- PC connexion .....USB 2.0/1.1 port

## VI. Programming Performance

**Table 8: Programming and verify in USB mode**

SPI Flash Densities	8Mbit	16Mbit	32Mbit	64Mbit	128Mbit	256Mbit	512Mbit	1Gbit
Program+ Verify	9s	11.6s	12.6s	31s	61.7s	89.2s	147.4s	444.3s
Reference IC	W25X80V SIG	W25Q16VS IG	W25Q32FVS IG	W25X64BV FIG	W25Q128B FIG	W25Q256FV FIG	S25FL512S DIF01	N25Q00AA 13GSF40F

Please note the programming and verify time will depends on different IC type; please refer to the IC specification before programming.

## VII. Revision History

Date	Version	Changes
2011/01/03	V1.0	First release.
2014/02/25	V2.0	Add SF600 <i>Plus</i> specification and standalone mode. Remove Isolation free.
2014/04/29	V2.1	1. Modify the COM port description 2. Supplement the socket adaptor plugging direction.
2014/05/08	V2.2	1. Supplement the COM port description.
2014/08/01	V2.3	1. Supplement the COM port of voltage description.
2016/01/20	V2.4	Programming Performance Update.
2016/03/14	V2.5	VCC description changed.
2017/07/28	V2.6	Modified document formats and changed company address.



## **DediProg Technology Co., Ltd**

**Taiwan Headquarter** TEL: 886-2-2790-7932 FAX: 886-2-2790-7916  
4F., No.7, Ln. 143, Xinming Rd., Neihu Dist., Taipei City 114, Taiwan

**China Office** TEL: 86-21-5160-0157  
Room 518, Building 66, Lane1333, Xinlong Road, Vanke Hongqiao CBD.Min Hang District,  
Shanghai, P.R.C. 201101

**U. S. Office** TEL: 1-909-274-8860  
209 E Baseline RD, Suite E208 #8, Tempe, AZ, 85283, USA

Technical Support: [support@dediprog.com](mailto:support@dediprog.com) Sales Support: [sales@dediprog.com](mailto:sales@dediprog.com)

Information furnished is believed to be accurate and reliable. However, DediProg assumes no responsibility for the consequences of use of such information or for any infringement of patents or other rights of third parties which may result from its use. Specifications mentioned in this publication are subject to change without notice.

This publication supersedes and replaces all information previously supplied.

All rights reserved  
Printed in Taiwan.